

### Advanced business platform

The Shuttle XPC Barebone SA76G2 with AMD RS760 chipset is designed to support AMD multi-core processors with AM2+ and AM3 socket and the integrated 3D graphics engine supports the breathtaking Windows Aero™ 3D visual interface of Windows Vista. With 5.1 audio, Gigabit LAN, SATA 3 Gb/s and low noise heat-pipe cooling engine this barebone is a great choice for an advanced business PC.

### »XPC Barebone SA76G2



Feature Highlight	
G2 chassis	<ul style="list-style-type: none"> <li>Aluminum chassis (black)</li> <li>Bays: 1x 5.25", 2x 3.5"</li> </ul>
Chipset	<ul style="list-style-type: none"> <li>AMD chipset: AMD RS760 + SB710</li> <li>Integrated Direct10 graphics engine with DVI- and VGA video outputs</li> <li>Supports up to 4 independent displays with additional applicable graphics card</li> </ul>
CPU	<ul style="list-style-type: none"> <li>Supports AMD Phenom II, Phenom, Athlon 64 X2, Athlon 64 and Sempron Processors with socket AM2, AM2+ and AM3 up to 105W TDP.</li> <li>Supports HyperTransport Version 3.0</li> <li>Shuttle I.C.E. Heatpipe-cooling</li> </ul>
Slots	<ul style="list-style-type: none"> <li>1x PCI-Express V2.0 (x16)</li> <li>1x PCI (32 Bit)</li> </ul>
Memory	<ul style="list-style-type: none"> <li>Supports 2x DDR2-533/667/800</li> <li>Supports up to a total size of 8 GB</li> </ul>
Drive connectors	<ul style="list-style-type: none"> <li>3x Serial-ATA 3 Gb/s, RAID</li> <li>1x IDE ATA 133</li> </ul>
Other connectors	<ul style="list-style-type: none"> <li>5.1 channel HD audio</li> <li>USB 2.0 (2x front, 4x rear, 6x onb.)</li> <li>GigaBit LAN</li> </ul>
Power supply	<ul style="list-style-type: none"> <li>Efficient 250 Watt mini power supply</li> </ul>
Application	<ul style="list-style-type: none"> <li>Business</li> </ul>



8 11686 00291 8

Shuttle Order No: PC-SA76G2

Images for illustration purposes only.

© 2009 by Shuttle Computer Handels GmbH (Germany). All Information subject to change without prior notice. Pictures for illustration purposes only.

## Shuttle XPC Barebone SA76G2 – Special Product Features

**XPC**



**PCI EXPRESS**

The Shuttle XPC series is the keyword in artistic design from Shuttle.

There are different chassis designs to choose from. No matter whether it's for use in the home or the office, for high adrenaline or laid back users, there is a Shuttle Mini-PC in the XPC series to suit every taste. Cover and front plate of the G2-design chassis are completely made of aluminum. This leads to a stylish-robust appearance and makes it to a popular design for many users.

### SA76G2 supports AMD Phenom II Processors

Realize new possibilities for connecting with friends, family, and digital entertainment with the phenomenal performance of the AMD Phenom and Phenom II series quad-core processor. Built from the ground up for true quad-core performance, AMD Phenom processors speed through advanced multitasking, critical business productivity, advanced visual design and modeling, serious gaming, and visually stunning digital media and entertainment.

### Integrated Cooling Engine (I.C.E.)

Shuttle's XPCs offer the power of a desktop PC in a form factor one-third the size. In order to ensure proper airflow inside a smaller unit, more advanced cooling technologies have been developed and implemented in the Shuttle XPC. Shuttle's industry-leading I.C.E. heatpipe technology delivers efficient cooling and is exceptionally quiet.

### Supports up to 8GB DDR2 800 Dual Channel Memory

The SA76G2 features 2x DDR2 memory slots and supports up to 8GB of RAM. It is optimized for future high-memory-demand applications such as high definition video and games.

### ATI SurroundView™ Technology

The Shuttle XPC Barebone SA76G2 features ATI Hybrid Graphics technology which enables ATI SurroundView™ multi-monitor technology, providing support for 4 independent monitors when an applicable integrated GPU is combined with a discrete GPU. It means you can definitely work under the environment with better desktop productivity and ultimate flexibility at the same time.

### PCI-Express V2.0 for high-performance graphics cards

The Shuttle XPC Barebone SA76G2 is equipped with one PCI-Express x16 Version 2.0 slot delivering a bandwidth of up to 16GB/s, twice the speed of PCI-E 1.0, thus providing plenty of potential for the newest graphics cards. It is downward compatible, allowing use for most of the present graphics cards as well.

## Shuttle XPC Barebone SA76G2 Specification

<i>Chassis</i>	G2-type aluminum chassis, black color storage bays: 1 x 5.25", 2 x 3.5" (1 internal) dimensions: 30 x 20 x 18.5 cm (LWH), weight: 3.3 kg net / 4.6 kg gross
<i>Mainboard</i>	Shuttle FA76, Shuttle form factor, 6 layers Proprietary mainboard design for Shuttle XPC Barebone SA76G2 Chipset: AMD RS760 + SB710 Dimensions: 25.4 x 18.5 cm
<i>Power Supply</i>	250 Watt mini power supply unit Input voltage range: 100~240V Connectors: 20-pin ATX, 4-pin ATX12V Dimensions: 190 (L) x 82 (W) x 43 (H) mm EMI certified: FCC, CE, BSMI, CCC Safety certified: UL, TÜV, CB, BSMI, CCC Active PFC (Power Factor Correction)
<i>Processor Support</i>	Supports AMD Processors with AM2, AM2+ and AM3 socket: AMD Phenom II, Phenom, Athlon 64 X2, Athlon 64, Sempron processors 2.6 GHz HyperTransport v3.0 Technology x16 Up/Down links CPU power consumption (TDP) = max. 105W Please refer the support list for detailed processor support information.
<i>Processor Cooling</i>	Shuttle I.C.E. (Integrated Cooling Engine) advanced I.C.E. Heatpipe technology, linear controlled 92mm fan SilentX cooling and noise reduction technology with Active Airflow
<i>Memory Support</i>	2 x 240 pin slots, supports Dual Channel supports DDR2-533/667/800 SDRAM unbuffered memory up to a total size of 8 GB, max. 4 GB per DIMM
<i>Expansion Slots</i>	1x PCI-Express V2.0 (16X) supports single-slot graphics cards 1x PCI (32 bit)
<i>Integrated Graphics</i>	Integrated graphics engine ATI Radeon 3000 (RV610, 350 MHz) DirectX 10.0 support, Shader Model 4.0, OpenGL 2.0 Shared Memory max. 256MB Maximum resolution: 2560x1440 at 75 Hz for 16:9 format Video outputs: digital DVI (single-link) and analog VGA Supports Dual independend display mode Supports Quad display mode with an additional applicable ATI graphics card

© 2009 by Shuttle Computer Handels GmbH (Germany). All information subject to change without prior notice. Pictures for illustration purposes only.

<p><i>5.1 channel Audio</i></p>	<p>Audio Realtek® ALC 662 6-channel High-Definition Audio            Three analog audio connectors (3.5mm) at the Back-Panel:            1) Front Line out (head phone)            2) Rear Surround line-out (shared with microphone input)            3) Center line-out (shared with Line in)            S/PDIF I/O available as onboard header</p>
<p><i>Gigabit-LAN Controller</i></p>	<p>Marvell 88E8057 Ethernet network controller (Gigabit PNY)            Supports 100 / 1.000 MBit/s operation            Supports Wake-on-LAN (WOL)</p>
<p><i>Drive connectors</i></p>	<p>3x Serial-ATA II, 3 Gbit/s (300 MB/s) bandwidth            1x IDE UltraDMA 133 drives</p>
<p><i>Front panel connectors</i></p>	<p>Microphone            Headphone (Line-out)            2x USB 2.0            Power button            Reset button            Power indicator (blue LED)            HDD indicator (orange LED)</p>
<p><i>Back panel connectors</i></p>	<p>DVI video output            VGA video output (Sub-D)            4x USB 2.0            GigaBit LAN (RJ45)            PS/2 keyboard            Audio connectors: 6-ch line-out (or Mic, Line-in, Line-out)            optional optical S/PDIF input/output (PC17)            optional Wireless LAN module (PN18)            optional parallel port (PC8)</p>
<p><i>Other onboard connectors</i></p>	<p>2x fan connectors (4 pin and 3 pin)            4x USB 2.0 (three times 2x5 pins)            Header for optional PS10 adapter (this adapter can be installed in the printer port perforation in the back panel and provides PS/2 keyboard and mouse ports)            Serial interface (RS-232, 2x5 pins)            Parallel interface onboard            S/PDIF in/out, audio line input (AUX)            Clear CMOS jumper            CIR header</p>
<p><i>Accessories</i></p>	<p>Multi-language installation guide            Driver CDROM for Windows XP/Vista (32/64 bit)            Cable for SATA (1x), PATA (1x)            Power cord            Screws</p>

© 2009 by Shuttle Computer Handels GmbH (Germany). All Information subject to change without prior notice. Pictures for illustration purposes only.

## Shuttle XPC Barebone SA76G2 – Connectors and Components

Front View



- (1) 5.25" bay
- (2) 3.5" bay
- (3) Hard disk LED
- (4) Power LED
- (5) Reset button
- (6) Power button
- (7) Microphone input
- (8) Headphone output
- (9) USB ports

Rear View

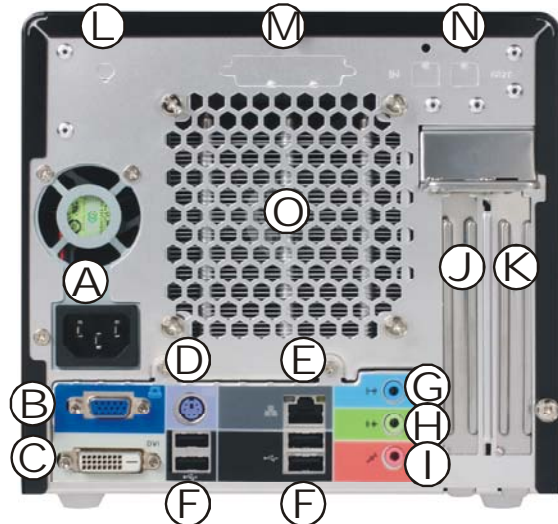

- (A) Power supply
- (B) VGA video port
- (C) DVI video port
- (D) PS/2 keyboard port
- (E) Gigabit LAN port
- (F) 4x USB ports
- (G) Audio Line-In
- (H) Audio Line-Out
- (I) Microphone input
- (J) PCI slot
- (K) PCI-Expr. x16 slot
- (L) WLAN perforation
- (M) Parallel port perforation
- (N) S/PDIF output perforation
- (O) Heatpipe cooling

Back panel connectors

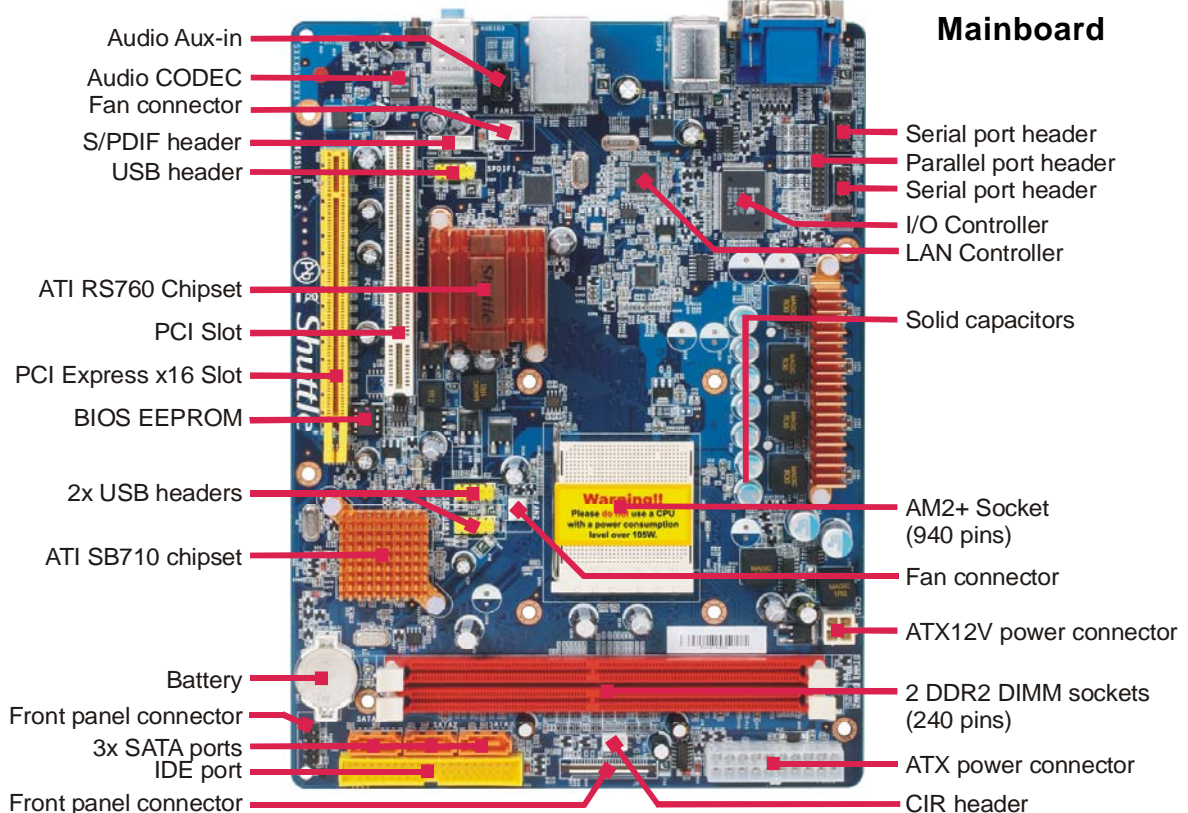

Mainboard

© 2009 by Shuttle Computer Handels GmbH (Germany). All information subject to change without prior notice. Pictures for illustration purposes only.

**Shuttle XPC Barebone SA76G2 – Optional Accessories**



**PF60 – Carrying Bag**



**PC23 – 3.5” Card Reader**



**PN20 – Wireless LAN**



**PC8 – Parallel Port Adapter**



**PC17 – Optical S/PDIF Output**



**PC60 – 300W Silent-X Power Supply  
Top efficiency with 80PLUS label**